

ADDENDUM NO. 1
Fantasy Forest 2.0 Playground Installation & Sitework

To all prospective bidders and others concerned:

YOU ARE HEREBY ADVISED THAT the Contract Documents for the above referenced Project are revised in the following particulars:

Page	Description of Change
00 01 10-1	Section 00 45 13 has been removed from the Table of Contents. This section was not included in the original bid documents but previously was listed in the Table of Contents.
00 42 43-3	Quantities for bid items number 31 and 34 have been updated.

Sheet	Description of Change
C-3.1	Location of 4 signs to be provided by Owner and installed by Contractor as part of Bid Item #2 have been drawn in. Detail for installation is provided on sheet C-5.1.
C-5.1	Detail for In-Ground Sign Mount has been provided.
L-1.0	Additional plantings are shown near the playground's east entrance.
L-2.1	Quantities for plants <i>Physocarpus opulifolius</i> and <i>Chasmanthium latifolium</i> have been updated.

General/Clarifications:

1. **Q** – In reviewing the documents for this project we found the following specification section is missing: 00 45 13 - Statement of Bidder's Qualifications. Was this section supposed to be included for this project?
A – This section was not intended to be included and has been removed from the Table of Contents.

2. **Q** – Would you please provide a cost estimate/budget and current plan holder list for the subject solicitation? In addition, what is the construction timeline including start and end dates?
A – A cost estimate/budget is not being publicly released for this project and no official plan holders list exists. The construction timeline includes construction beginning as soon as possible beginning in May 2025. Playground and other equipment will be delivered to the site in April. Substantial completion is set to be September 12th, 2025 and final completion is set as September 26th 2025.

3. **Q** – I am checking in on this project to confirm the bid date remains unchanged.
A – The bid due date is unchanged. It remains Thursday, February 6th. Bids can be emailed as detailed in the bid documents.

This Addendum is hereby incorporated into the original Contract Documents for the bidding referred to above and is considered as binding as though originally appearing therein. Receipt of this Addendum must be noted in the place provided on the Proposal page 00 4243-1 dated 01/31/2025.



PRE-BID MEETING AGENDA

Meeting Topic: Fantasy Forest 2.0 Playground Installation and Site Work, City of St. Johns, Michigan

Date: Tuesday, January 28, 2024

Time: 10:00 AM

Location: Microsoft TEAMS

Welcome:

1. Please sign-in sheets via the meeting chat function.
2. Minutes from this meeting (and a copy of the sign-in) will be distributed as part of Addendum No. 1

Introductions:

1. Owner: City of St. Johns, Michigan
Recreation Director William Schafer
Public Services Director Justin Smith
City Manager Chad Gamble, PE
2. Engineer/Landscape Architect: Wade Trim, Inc.
Catherine Dennis, PLA, Project Manager
3. Playground Designer and Supplier: Great Lakes Recreation
Stephanie Habers

Project Summary:

1. In fall 2024, a previous phase to this project included purchase and delivery for all playground equipment and site furnishings needed to construct the replacement playground referred to as Fantasy Forest 2.0 at St. Johns City Park in St. Johns Michigan. Great Lakes Recreation was the successful bidder on this work and will be a key partner for this current phase of the Fantasy Forest 2.0 Playground Installation and Site Work project.
2. This Project, known as Fantasy Forest Playground Improvements, includes, but is not limited to the installation of playground equipment, benches, litter bins, and a water fountain purchased as part of a separate project. The project also includes grading and drainage, connecting concrete paths and other improvements. Proposed landscape plantings will be purchased but not installed in this project; installation will follow as part of a community work day.

Work will also include site restoration and other Work necessary to complete the project. Significant coordination will be required during this project between Contractor, City of St. Johns staff, representatives from Great Lakes Recreation, representatives of ESM, lighting and electrical contractor, and asphalt installer. Coordination efforts will be provided by Contractor incidental to the project.

The site is located on the west side of St. Johns Park Rd, inside St. Johns City Park in the City of St. Johns, Michigan, as shown on the Drawings. The Bidder must figure its Base Bid and Additive Alternate Bids on the specified, or Addendum-approved, materials and equipment only. No "or equal" or substitution proposals will be permitted after Bid opening, except as provided in the General Conditions.

3. Bids will be received by the City of St. Johns through email to the City Clerk Mindy Seavey, mseavey@stjohnsmi.gov, until 3:00 PM, Local Time, 02-06-2025. It is the responsibility of bidder to verify bid has been received by City Clerk. Shortly after the bid closing time a bid tabulation will be prepared and posted online.

Bidding Process:

1. Contract Documents may be examined at the following locations:
 - a. City of St. Johns, 100 E State St, Suite 1100, St. John's MI 48879
 - b. Builders Exchange of Central Michigan, 1240 East Saginaw, Lansing, MI 49504
 - c. Wade Trim Associates, 500 Griswold Avenue, Suite 2500, Detroit, MI 48226
2. Contract Documents are also available for viewing online at:
www.wadetrim.com/resources/bid-tab/.
3. Bids will be received by the City of St. Johns through email to the City Clerk Mindy Seavey, mseavey@stjohnsmi.gov, until 3:00 PM, Local Time, 02-06-2025. It is the responsibility of bidder to verify bid has been received by City Clerk. Shortly after the bid closing time a bid tabulation will be prepared and posted online.

Contract Requirements:

1. Bidder's Qualifications (Section 002113, Article 1.02)): Indicates information regarding bidder's qualifications to perform the work must be submitted after Owner request.
2. Examination of Site (Section 002113, Article 1.02): Bidders should familiarize themselves with the site and the laws and regulations that may affect cost, progress, performance, or furnishing of the Work.
3. Bid Security (Section 002113, Article 1.06): 5% of the Bidder's maximum price in the form of a Bid Bond or Cashier's Check. If the Successful Bidder fails to execute and deliver the Contract Documents and to furnish the required Contract security within twenty (20) days after the Notice of Award, Owner may annul and cancel the Notice of Award, and the Bid security of that Bidder shall be forfeited and retained by the City of St. Johns.
4. Substitutions (Section 002113, Article 1.08):
 - a. The Contract, if awarded, will be on the basis of materials and equipment proposed to execute the design described in the Plans or specified in the Specifications to substantially match in layout and in theme the enclosed Master Plan. A detailed list of equipment required to build the playground design as-submitted in the Master Plan Bid will be provided by Contractor in the completed Proposal form in Section 00 42 43.
 - b. Contractor is welcome to submit Bids reflecting alternate layouts and themes for the consideration of award as an alternate bid proposal. In such a case, Contractor will provide an additional completed Proposal form in Section 00 42 43 showing a detailed list of equipment required to build the alternative playground design.
 - c. Acceptance of substitute or an "or equal" item of material is at the sole discretion of the Owner or designated Representative.
5. Basis of Bid (Section 00200, Article 13):
 - a. The Bid price shall include such amounts as Bidder deems proper for overhead and profit on account of cash allowances, if any, named in the Contract Documents. Refer also to Article 11.07.C for calculation of overhead and profit allowed by the General Conditions.

- b. Bidder shall satisfy themselves of the accuracy of the estimated quantities in the Bid by examination of the Site and a review of the Drawings and Specifications, including the Addenda.
 - c. Unit Prices bid, shall include such amounts as the Bidder deems proper for overhead, profit, taxes, General Conditions and such other incidentals as noted in the Contract Documents.
 - d. The City of St. Johns may increase or decrease the contract quantities in the amount of not more than twenty-five percent (25%) of each item on a Unit Price Work contract without an increase in unit price.
6. Contract Time (Section 005200, Article 1.03): Work will be substantially completed by September 12, 2025 and final completion will occur by September 26, 2025.
 - a. The City of St. Johns hosts the annual Mint Festival in early August. It is the responsibility of the Contractor to keep the project site secure during the duration of the festival.
7. Insurance Requirements (as specified in General Conditions Article 5): Sample Certificate for Liability Insurance, including minimum insurance limits.
8. Contractor's Application for Payment (Section 01 3300 Article 1.05): Contractor shall submit a completed Payment Schedule with an executed Contractor's Application for Payment and Contractor's Declaration to Engineer not more often than once per month. Engineer will certify payments with the use of Engineer's Certificate for Payment.
 - a. Payment Procedures (Section 00 5200 Article 1.05): The first progress payment under this contract may be requested after the equipment has been ordered by the Contractor. At this time, 50% of the total contract price can be requested for payment. The remaining balance of payment can be requested by the Contractor upon materials delivery.

Alternates, Allowances & Unit Prices:

1. This project includes the base bid playground as shown on sheet C-2.0 of the construction plans. Additionally, there are additive alternatives 1, 2, and 3 as shown on the same sheet.
2. There are two allowances in this bid.
 - a. Construction Staking: Construction Staking will be provided as an allowance to be paid to the Owner's Representative at their actual invoiced cost. This payment shall constitute compensation for the labor, materials, and equipment required for a licensed Professional Surveyor to perform surveying activities in accordance with industry standards. An allowance of \$25,000 has been established for the Contractor to coordinate the project staking with the Engineer.
 - b. Contingency, 5% of Project Cost, to cover costs to unforeseen work which may arise during the course of construction and will only be used at the Owner's direction. This allowance is for unforeseen work which may arise during the course of construction and will only be used at the Owner's direction.
3. Unit Prices can be found in Section 01 22 00 (page 102 Project Manual)

Significant Project Issues:

1. Bid Opening: Sealed Bids will be received by the City of St. Johns Clerk's Office via mail or hand delivery until 3:00 PM, Local Time, Thursday, October 10, 2024. In the days following the bid closing time a bid tabulation will be prepared and posted online.
2. Project Schedule:
 - a. Optional Pre-Bid Meeting January 28, 2025, 10:00 AM

- b. Bids Due: February 6, 2025, 3:00 PM
 - c. Anticipated Contract Award: March 2025
 - d. Anticipated Notice to Proceed: March 2025
 - e. Substantial Completion: September 12, 2025
 - f. Final Completion: September 26, 2025
3. Permits:
- a. The Contractor must submit Soil Erosion and Sedimentation Control permit to Clinton County and secure permit as well as take other measures necessary to comply with all required soil erosion and sedimentation control measures.
4. Addenda:
- a. Addendum No. 1 will be issued and will include pre-bid meeting minutes, revised specifications, reissued Contract Drawings, and any other contract documents necessary for clarification.
5. Communication:
- a. Communications concerning bids shall be addressed to Catherine A. Dennis, PLA and must be submitted in writing (CDennis@wadetrim.com).

Questions from the Attendees:

Meeting Adjourned:

Attendees: Stephanie Haber – Great Lakes Recreation (Playground Designer), Bill Schafer (Recreation Director), Katie Dennis (WT), Jordan White (WT)

**SECTION 00 01 10
TABLE OF CONTENTS**

PROCUREMENT AND CONTRACTING REQUIREMENTS

DIVISION 00 - PROCUREMENT AND CONTRACTING REQUIREMENTS

- 00 0100 - Cover
- 00 01 10 - Table of Contents
- 00 01 15 - List of Drawing Sheets
- 00 11 13 - Advertisement for Bids
- 00 21 13 - Instructions to Bidders
- 00 4243 - Proposal
- 00 43 13 - Bid Bond Form
- 00 4345 - Legal Status of Bidder
- ~~00 45 13 - Statement of Bidder's Qualifications~~
- 00 5100 - Notice of Award
- 00 52 00 - Agreement
- 00 5500 - Notice to Proceed
- 00 6112 - Performance Bond (MI)
- 00 6113 - Labor and Material Payment Bond (MI)
- 00 61 19 - Maintenance and Guarantee Bond
- 00 6275 - Engineer's Certificate for Payment
- 00 6276 - Contractor's Application for Payment
- 00 6277 - Payment Schedule
- 00 6325 - Substitution Request Form
- 00 6370 - Change Proposal Form
- 00 6516 - Certificate of Substantial Completion Form
- 00 6520 - Sworn Statement
- 00 72 00 - General Conditions
- 00 73 00 - Supplementary Conditions
- 00 91 13 - Addendum Form

SPECIFICATIONS

DIVISION 01 - GENERAL REQUIREMENTS

- 01 11 00 - Summary of Work

- 01 21 00 - Allowances
- 01 22 00 - Unit Prices
- 01 31 19 - Project Meetings
- 01 33 00 - Submittal Procedures
- 01 4500 - Quality Control
- 01 50 00 - Temporary Facilities and Controls
- 01 57 13 - Temporary Erosion and Sediment Control
- 01 60 00 - Product Requirements
- 01 71 23.26 - Construction Layout and Staking
- 01 77 00 - Closeout Procedures
- 01 89 00 - Site Construction Performance Requirements

DIVISION 02 - EXISTING CONDITIONS

- 02 41 13 - Selective Demolition

DIVISION 03 - CONCRETE

- 03 1100 - Concrete Forming
- 03 1500 - Concrete Accessories
- 03 20 00 - Concrete Reinforcing
- 03 30 00 - Cast-in-Place Concrete

DIVISION 04 - MASONRY

DIVISION 05 - METALS

DIVISION 06 - WOOD, PLASTICS, AND COMPOSITES

DIVISION 07 - THERMAL AND MOISTURE PROTECTION

DIVISION 08 - OPENINGS

DIVISION 09 - FINISHES

DIVISION 10 - SPECIALTIES

DIVISION 11 - EQUIPMENT

- 11 68 13 - Playground Equipment

DIVISION 12 - FURNISHINGS

DIVISION 13 - SPECIAL CONSTRUCTION

DIVISION 14 - CONVEYING EQUIPMENT

DIVISION 21 - FIRE SUPPRESSION

DIVISION 22 - PLUMBING

DIVISION 23 - HEATING, VENTILATING, AND AIR-CONDITIONING (HVAC)

DIVISION 25 - INTEGRATED AUTOMATION

DIVISION 26 - ELECTRICAL

DIVISION 27 - COMMUNICATIONS

DIVISION 28 - ELECTRONIC SAFETY AND SECURITY

DIVISION 31 - EARTHWORK

31 1100 - Clearing and Grubbing

31 22 00 - Grading

31 2313 - Subgrade Preparation

31 2333 - Trenching and Backfilling

DIVISION 32 - EXTERIOR IMPROVEMENTS

32 11 23 - Aggregate Base Courses

32 1216 - Bituminous Paving

32 13 13 - Concrete Paving

32 1315 - Sidewalks and Driveways

32 15 00 - Aggregate Surfacing

32 17 13 - Parking Bumpers

32 17 23 - Pavement Markings

32 18 16.13 - Playground Protective Surfacing

32 3100 - Fences and Gates

32 90 00 - Planting

32 92 19 - Seeding

32 93 00 - Bioswales - Bioretention

DIVISION 33 - UTILITIES

33 1100 - Water Utility Distribution Piping

33 4100 - Storm Utility Drainage Piping

DIVISION 34 - TRANSPORTATION

DIVISION 40 - PROCESS INTEGRATION

DIVISION 46 - WATER AND WASTEWATER EQUIPMENT

APPENDIX A - PLAYGROUND SPECIFICATIONS AND WARRANTY
INFORMATION

END OF SECTION

**SECTION 00 42 43
PROPOSAL**

PART 1 GENERAL

1.1 OWNER

- A. City of St. Johns
- B. Fantasy Forest 2.0 Playground
- C. Saint Johns, Michigan, 48879

1.2 PROJECT

- A. Fantasy Forest 2.0 Playground Installation and Site Work

1.3 BIDDER INFORMATION

- A. Bidder
Name: _____
- B. By (Printed
Name): _____
- C. Signature: _____

- D. Address: _____

- E. Phone
No: _____
- F. Email: _____
- G. The Bidder proposes and agrees, if their Bid is accepted, to enter into an Agreement with the City of St. Johns in the form included in the Contract Documents to complete all Work as specified or indicated in the Contract Documents for the Contract Price and within the Contract Time indicated in the Agreement, and in accordance with the Contract Documents.
- H. In submitting their Bid, Bidder represents, as more fully set forth in the Agreement, that;
 - 1. Bidder has examined copies of all Contract Documents, (consisting of Plans dated January 16, 2025 and Project Manual dated January 2025) which he understands and accepts as sufficient for the purpose, including any and all Addenda officially issued, the receipt of which has been acknowledged.
 - 2. Bidder has examined the surface and subsurface conditions where the Work is to be performed, the legal requirements and local conditions affecting cost, progress, furnishing or performance of the Work, and has made such independent investigations as Bidder deems necessary.
 - 3. Their Bid is genuine and not made in the interest of or on behalf of any undisclosed person, firm or corporation and is not submitted in conformity with any Agreement

or rules of any group, association, organization or corporation; Bidder has not directly or indirectly induced or solicited any other Bidder to submit a false or sham Bid; Bidder has not solicited or induced any person, firm or a corporation to refrain from bidding; and Bidder has not sought by collusion to obtain for himself any advantage over any other Bidder or over the Owner.

- I. The Bidder agrees to complete the Work, in accordance with the Contract Documents, for the following Contract Price:

Item	Description	Unit	Quantity	Unit Price	Amount
1	Mobilization (5%)	LSUM	1	\$	\$
2	Project Signage	LSUM	1	\$	\$
3	Construction Staking	AL	1	\$25,000	\$25,000
4	Soil Erosion & Sedimentation Control	LSUM	1	\$	\$
Demolition					
5	Clearing and Grubbing	LSUM	1	\$	\$
6	Tree Protection Fence	LSUM	1	\$	\$
7	Construction Fence, 6' Ht.	LFT	1,440	\$	\$
Construction					
8	Site Grading	LSUM	1	\$	
9	Concrete Pavement, 4", Broom	SFT	7,700	\$	\$
10	Concrete 6" Curb & Gutter	LFT	153		
11	Concrete Border, 6" width, 12" depth	LFT	62	\$	\$
12	Aggregate Base, 8", 22A	CYD	41	\$	\$
13	Pavement Markings	LSUM	1	\$	\$
14	Barrier Free Sign	EACH	4	\$	\$
15	Poured-In-Place Rubber Surface	SFT	4,260	\$	\$
16	Engineered Wood Fiber Mulch	SFT	5,300	\$	\$
17	Water Service, 1" PEX with Tracer	LFT	364	\$	\$
18	Connection to Existing Water Main	EACH	1	\$	\$
19	Storm Sewer, Dual Wall HDPE 6" Perforated Underdrain	LFT	132	\$	\$
20	Underdrain Outlet Spreader, Complete	LSUM	1	\$	\$
21	Hydrant, Woodford Y95 5; Bury Box	EACH	3	\$	\$
22	Installed Complete, Bench	EACH	7	\$	\$
23	Installed Complete, Waste	EACH	4	\$	\$

Item	Description	Unit	Quantity	Unit Price	Amount
	Receptacle				
24	Installed Complete, Drinking Fountain, Most Dependable Fountains Model 10145	EACH	1	\$	\$
25	Installed Complete, Base Bid Playground Equipment	EACH	1	\$	\$
26	Landscape Boulders	EACH	6	\$	\$
27	Landscaping, Double Shredded Hardwood Mulch	EACH	6	\$	\$
28	Tree, Carpinus caroliniana, 2.5" Cal., Purchase Only	EACH	2	\$	\$
29	Tree, Fagus grandifolia, 2.5" Cal., Purchase Only	EACH	2	\$	\$
30	Shrub, Cephalanthus occidentalis, #3 Cont., Purchase Only	EACH	24	\$	\$
31	Shrub, Physocarpus opulifolius, #3 Cont., Purchase Only	EACH	26	\$	\$
32	Shrub, Staphylea trifolia, #3 Cont., Purchase Only	EACH	4	\$	\$
33	Perennial Fern, Athyrium filix-femina, #1 Cont., Purchase Only	EACH	60	\$	\$
34	Ornamental Grass, Chasmanthium latifolium, #1 Cont., Purchase Only	EACH	72	\$	\$
35	Restoration, Rain Garden Seedmix	SFT	1,706	\$	\$
36	Restoration, Woodland Seedmix	SFT	11,397	\$	\$
37	Restoration, Eco Turf Low Maintenance Fescue Seedmix	SFT	4,738	\$	\$
38	Contingency	AL		\$	\$

Total Contract Price (Items 1 through 38) \$ _____

Additive Alternate 1: Independent Play Area

1	Clearing and Grubbing	LSUM	1	\$	\$
2	Concrete Pavement, 4", Broom	SFT	72	\$	\$
3	Concrete Border, 6" width, 12" depth	LFT	168	\$	\$
4	Engineered Wood Fiber Mulch	SFT	3,400	\$	\$

5	Installed Complete, Bench	EACH	3	\$	\$
6	Installed Complete, Additive Alternate 1 Playground Equipment	LSUM	1	\$	\$

Total Alternate 1 Contract Price (Items 1 through 6) \$ _____

Additive Alternate 2: Tot Area

1	Clearing and Grubbing	LSUM	1	\$	\$
2	Concrete Pavement, 4", Broom	SFT	48	\$	\$
3	Concrete Border, 6" width, 12" depth	LFT	160	\$	\$
4	Poured-In-Place Rubber Surface	SFT	3,340	\$	\$
5	Installed Complete, Bench	EACH	2	\$	\$
6	Installed Complete, Additive Alternate 2 Playground Equipment	LSUM	1	\$	\$
7	Ornamental Fencing	LFT	175	\$	\$

Total Alternate 2 Contract Price (Items 1 through 7) \$ _____

Additive Alternate 3: Track Ride Feature

1	Clearing and Grubbing	LSUM	1	\$	\$
2	Concrete Border, 6" width, 12" depth	LFT	250	\$	\$
3	Poured-In-Place Rubber Surface	SFT	775	\$	\$
4	Engineered Wood Fiber Mulch	SFT	1,350	\$	\$
5	Installation Only, Additive Alternate 3 Playground Equipment	LSUM	1	\$	\$

Total Alternate 3 Contract Price (Items 1 through 5) \$ _____

- J. The Bidder by submitting a Bid, thereby certifies that he or a qualified designated person in his employ has examined the Contract Documents provided by the Owner for bidding purposes. Further, they certify that he or his qualified employee has reviewed the Bidder’s proposed construction methods and finds them compatible with the conditions which he anticipates from the information provided for Bidding.
- K. The Bidder by submitting a Bid agrees to complete the Work under any job circumstances or field conditions present and/or ascertainable prior to bidding. In addition, he agrees to complete the Work under whatever conditions he may create by his own sequence of construction, construction methods, or other conditions he may create, at no additional cost to the Owner.
- L. The Bidder by submitting a Bid, declares that he has familiarized himself with the location of the proposed Work and the conditions under which it must be constructed. Also, that he has carefully examined the Plans, the Specifications, and the Contract

Documents, which he understands and accepts as sufficient for the purpose, and agrees that he will Contract with the Owner to furnish all labor, material, tools, and equipment necessary to do all Work specified and prescribed for the completion of the Project.

- M. The Bidder by submitting a Bid agrees that if awarded Contract, to sign the Agreement and submit satisfactory bonds and certificates of insurance coverage and other evidence of insurance required by the Contract Documents within 15 days after the date of Owner's Notice of Award.
- N. The Bidder by submitting a Bid agrees that time is of the essence and, if awarded Contract, that the Work will be Completed on or before the dates/days as specified in the Agreement.
- O. Liquidated damages, as specified in the General Conditions, Supplementary Conditions and Agreement, shall also apply to the Substantial Completion date.
- P. Engineering and inspection costs incurred after the final completion date shall be paid by the Contractor to the Owner as specified in the Conditions of the Contract and Agreement.
- Q. Proposals may not be withdrawn for a period of 60 days after bid opening.
- R. The following documents are made a condition of this Proposal:
 - 1. Required Bid Security
 - 2. Legal Status of Bidder
 - 3. Non-Collusion Affidavit
 - 4. Certificate of Insurance

PART 2 PRODUCTS (NOT USED)

PART 3 EXECUTION (NOT USED)

END OF SECTION

PROJECT MANAGER: C:\PW_WORK\2024\101473817\CSP-PLT-SITE-PLAN.DWG - C-3.1 - PLOTTED 1/31/2025 10:16 AM BY DENNIS, MATIE

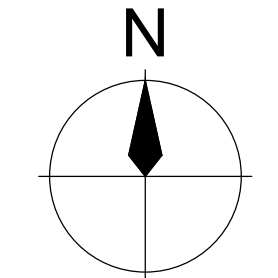
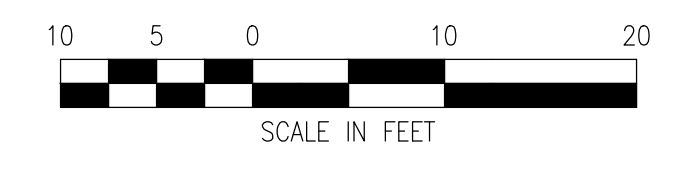
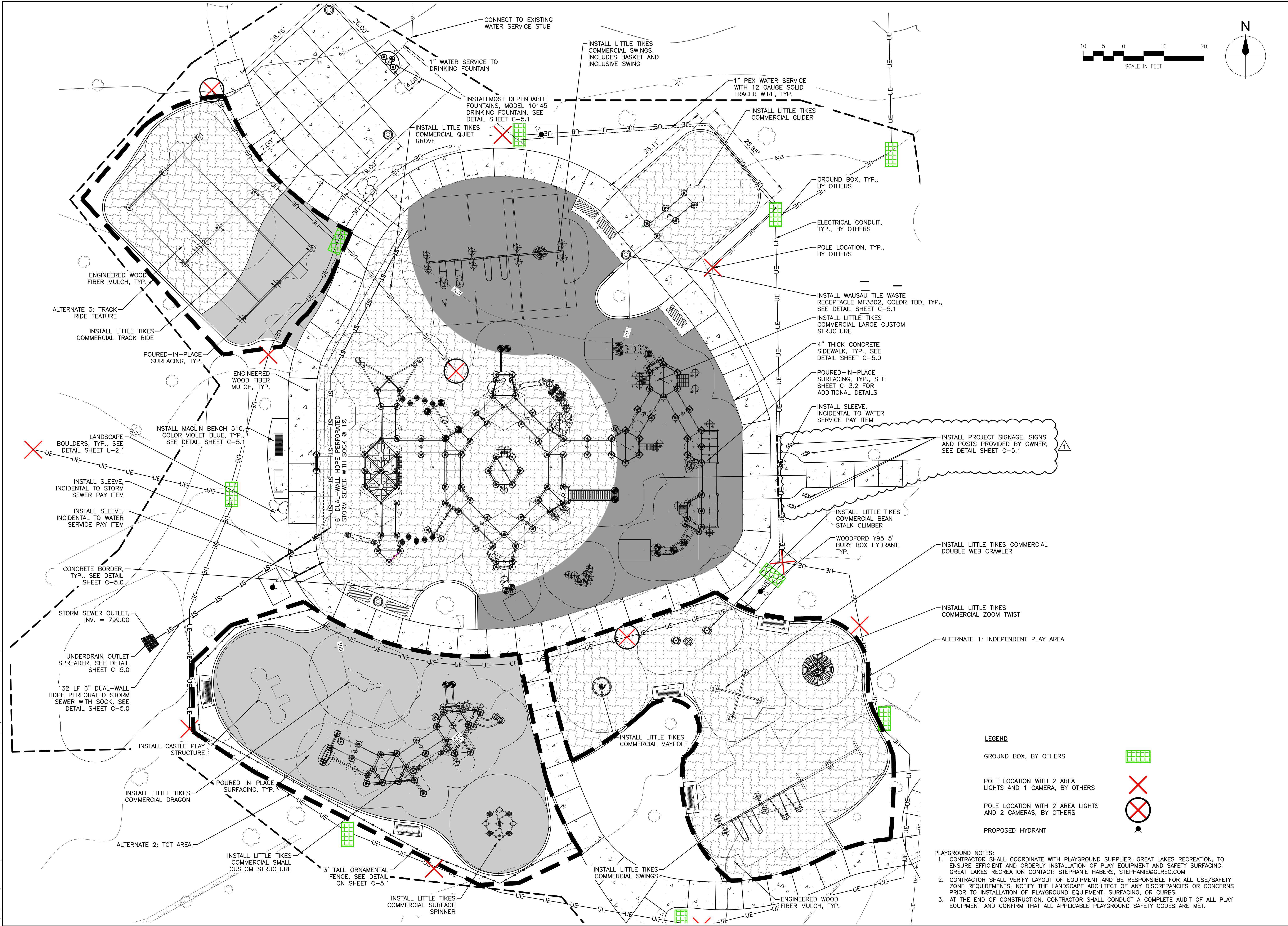

LEGEND

- GROUND BOX, BY OTHERS
- POLE LOCATION WITH 2 AREA LIGHTS AND 1 CAMERA, BY OTHERS
- POLE LOCATION WITH 2 AREA LIGHTS AND 2 CAMERAS, BY OTHERS
- PROPOSED HYDRANT

PLAYGROUND NOTES:

1. CONTRACTOR SHALL COORDINATE WITH PLAYGROUND SUPPLIER, GREAT LAKES RECREATION, TO ENSURE EFFICIENT AND ORDERLY INSTALLATION OF PLAY EQUIPMENT AND SAFETY SURFACING. GREAT LAKES RECREATION CONTACT: STEPHANIE HABERS, STEPHANIE@GLREC.COM
2. CONTRACTOR SHALL VERIFY LAYOUT OF EQUIPMENT AND BE RESPONSIBLE FOR ALL USE/SAFETY ZONE REQUIREMENTS. NOTIFY THE LANDSCAPE ARCHITECT OF ANY DISCREPANCIES OR CONCERNS PRIOR TO INSTALLATION OF PLAYGROUND EQUIPMENT, SURFACING, OR CURBS.
3. AT THE END OF CONSTRUCTION, CONTRACTOR SHALL CONDUCT A COMPLETE AUDIT OF ALL PLAY EQUIPMENT AND CONFIRM THAT ALL APPLICABLE PLAYGROUND SAFETY CODES ARE MET.

REV#	DATE	DESCRIPTION	CD	BY
1	1/31/25	ADDENDUM 1		

800 General Avenue, Suite 2000
313.961.8500
www.wadetrims.com

City of St. Johns
Fantasy Forest 2.0 Playground Improvements
Playground Installation and Sitework
SITE PLAN - PLAYGROUND ENLARGEMENT

ISSUED FOR: DATE: BY:
MNR Review 8/19/24 CD
90% Review 12/20/24 CD
Bid 01/16/25 CD

JOB NO. CSJ200101D

SHEET C-3.1

© Wade Trim Group, Inc. Fantasy Forest Playground Improvements

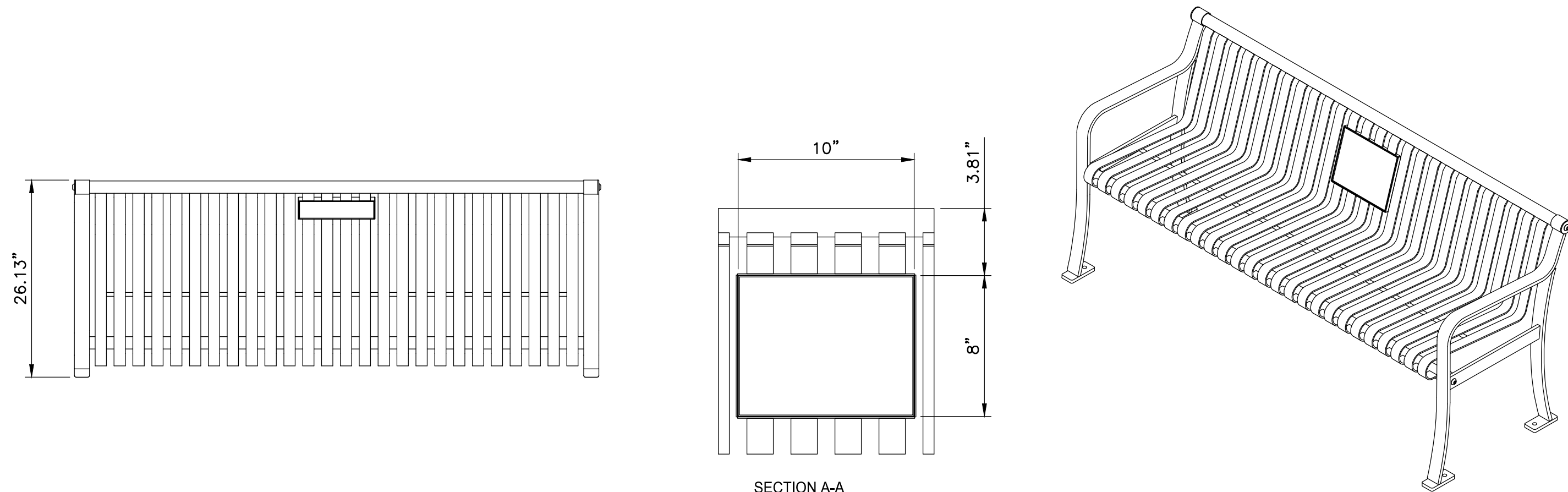

SECTION A-A
AL PLAQUE SIZE

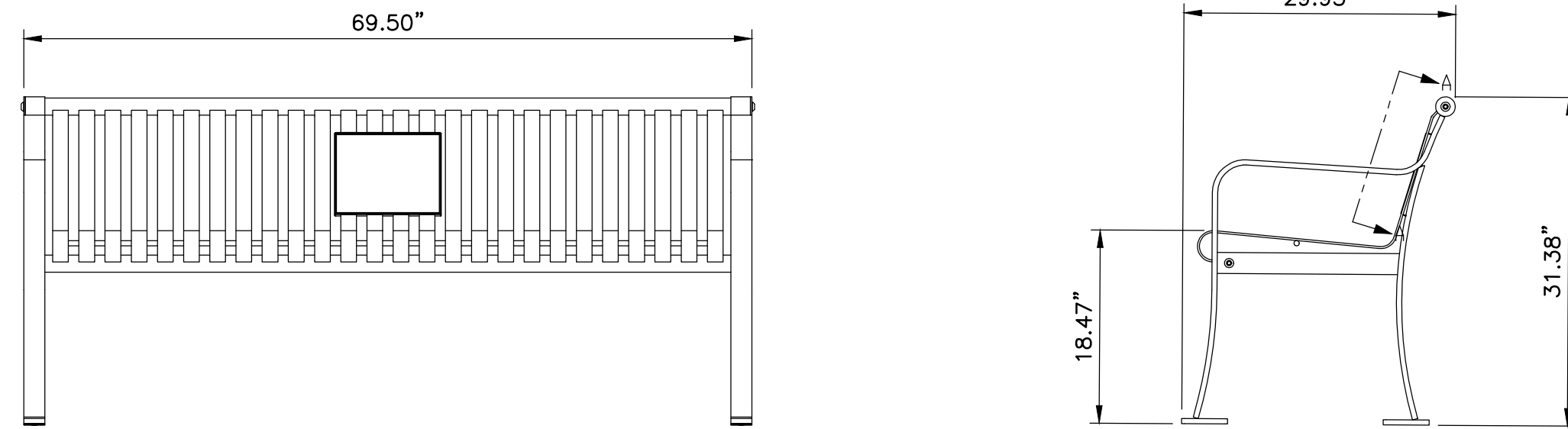

NOTE:
1. SURFACE MOUNT BENCH TO CONCRETE PAD PER MANUFACTURER'S INSTRUCTIONS.

MAGLIN 510 BENCH, 70IN L, STEEL ENDS, METAL, END ARMS, 10IN X 8IN PLQ AL.
ITEM: MMP-0510-00028, INSTALLATION DETAIL

NOT TO SCALE

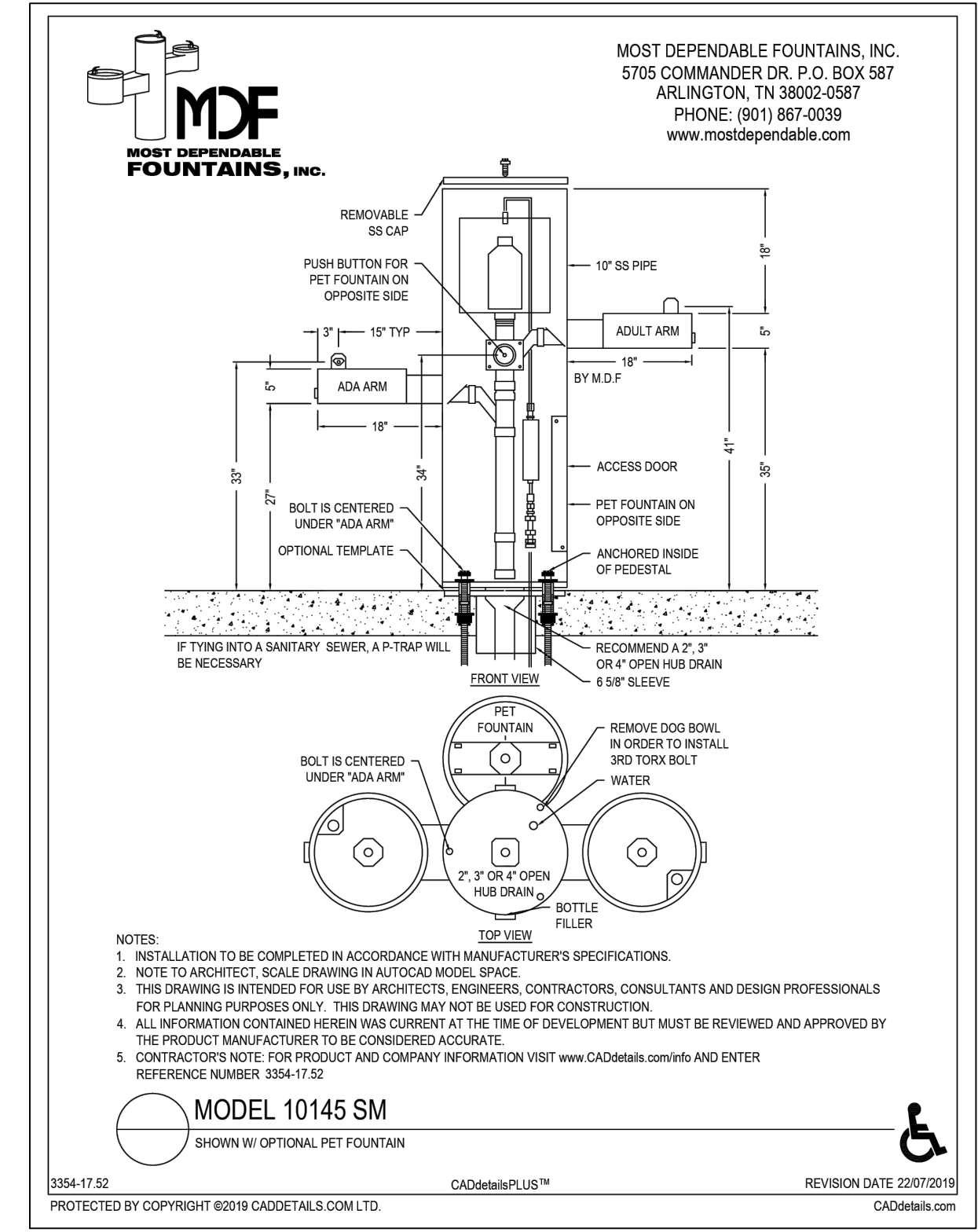

NOTE:
1. MOST DEPENDABLE FOUNTAINS MODEL 10145 DRINKING FOUNTAIN WITH PET FOUNTAIN. SURFACE MOUNT WITH 2" OPEN HUB DRAIN.

MODEL 10145 DRINKING FOUNTAIN
NO SCALE



NOTE:
1. SURFACE MOUNT LITTER BIN TO CONCRETE PAD PER MANUFACTURER'S INSTRUCTIONS.

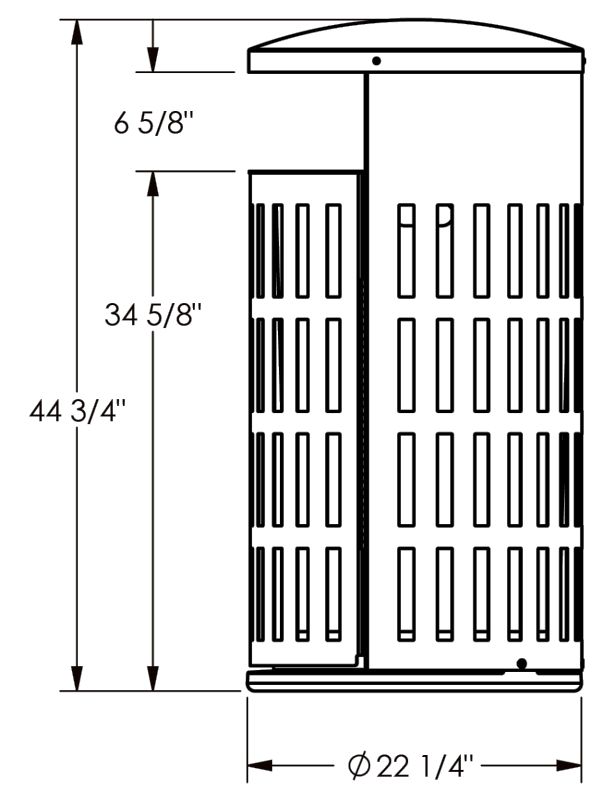
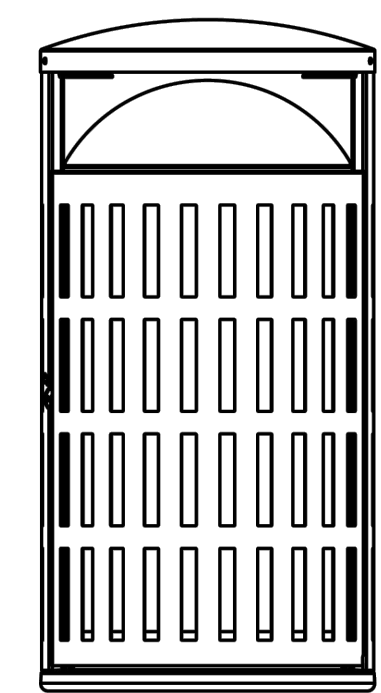
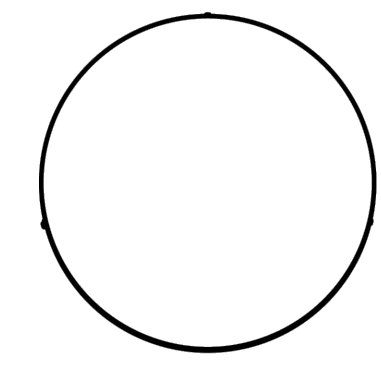

ITEM	PART NUM	DESCRIPTION	QTY
1	800993	ASSY SHELL	1
2	800994	ASSY DOOR	1
3	238951	COVER - 16 GA STEEL	1
5	351066	DIVIDER TRASH	1
13	800961	HINGE, 18" SS	1
14	800982	ASSY LOCK TAB	1
15	801001	ASSY LATCH	1
16	400295	RIVET, BLIND, Ø.12 X 3/16, 18-8 SS	9
17	400296	RIVET, BLIND, Ø.156 X .18, 18-8 SS	2
18	400105	NUT, K-LOCK, 10-24, SS	2

WASAU TILE LITTER BIN MF3302

NOT TO SCALE

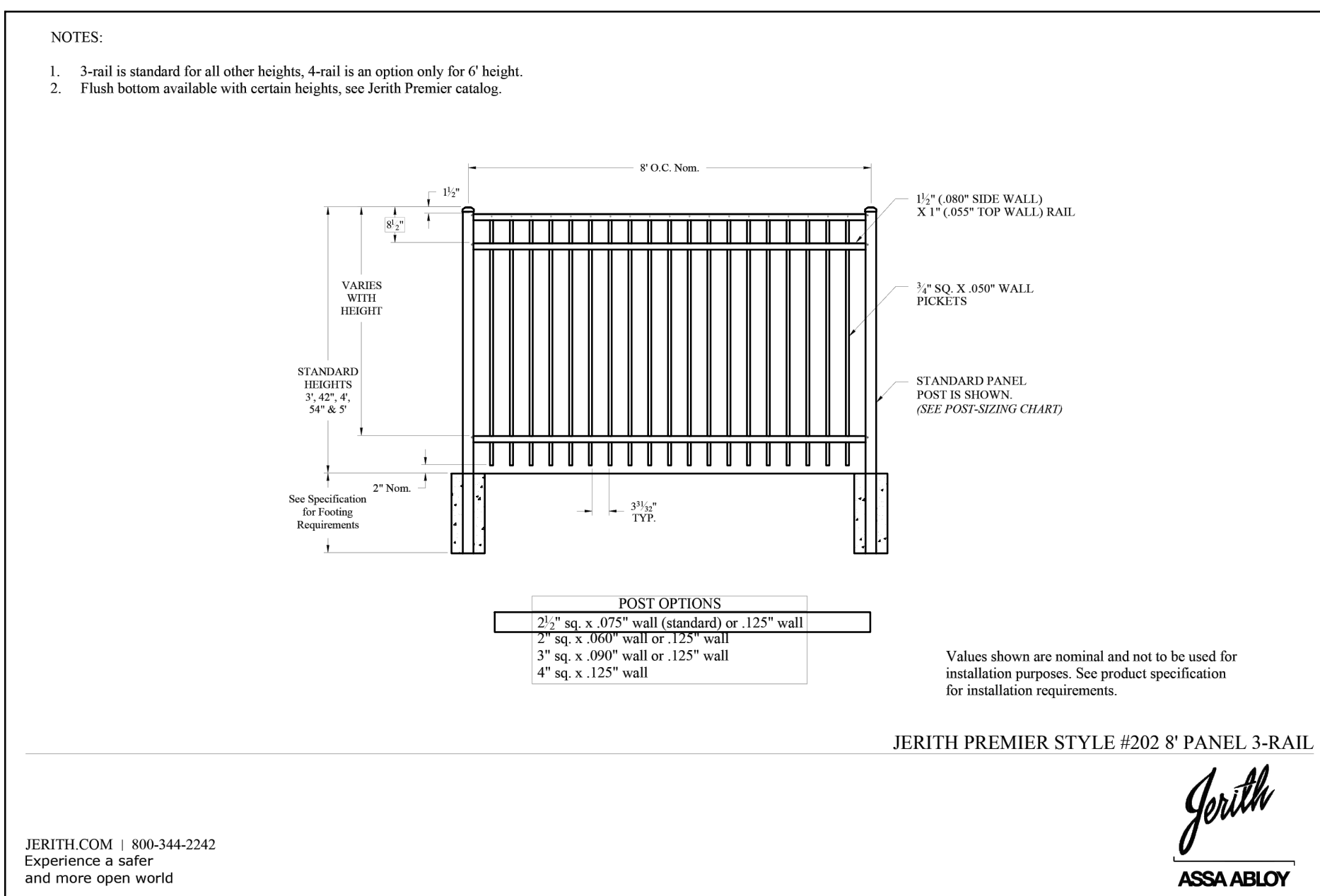

NOTE:
1. FENCE TO BE 3' TALL WITH STANDARD POST OPTION.

ORNAMENTAL FENCE DETAIL

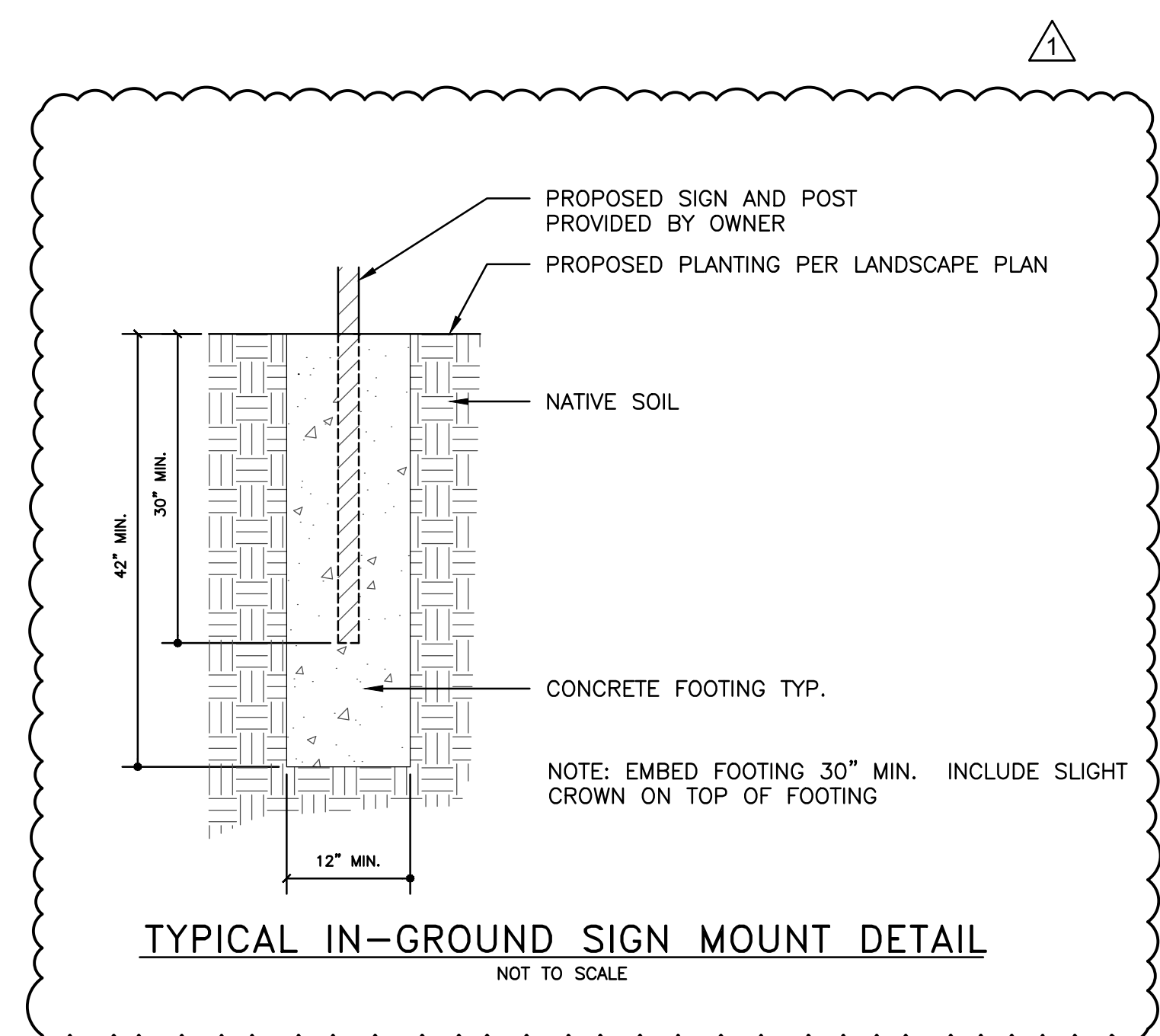

TYPICAL IN-GROUND SIGN MOUNT DETAIL

NOT TO SCALE

PROJECT MANAGER: C:\PW_MORRIS\1473817\GDT-PLTS-SITE DETAIL.DWG - C-5.1 - PLOTTED 1/31/2025 9:44 AM BY DENNIS, KATIE

REV#	DATE	DESCRIPTION
1	1/31/25	ADDENDUM 1

800 Greenhill Avenue, Suite 2000
Arlington, TN 38002-0587
313.961.3550
www.wadetrims.com

WADE TRIM

City of St. Johns
Fantasy Forest 2.0 Playground Improvements
Playground Installation and Sitework
SITE DETAILS

ISSUED FOR:	DATE:	BY:
MDNR	8/19/24	CD
90% Review	12/20/24	CD
Bid	01/16/25	CD
JOB NO.	CSJ200101D	
SHEET	C-5.1	

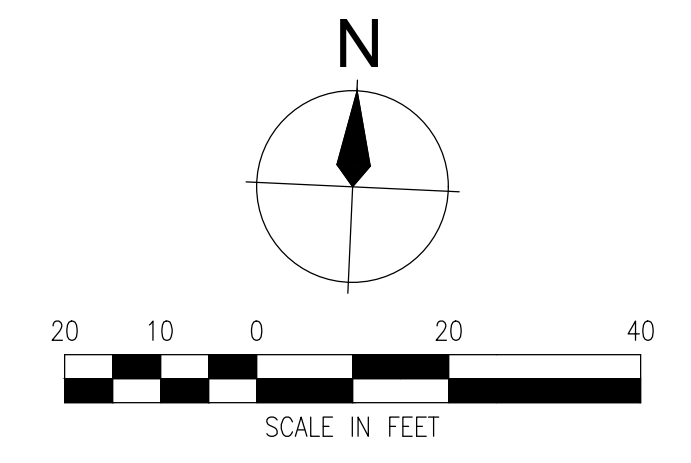

© Wade Trim Group, Inc. Fantasy Forest Playground Improvements

PROJECT MANAGER: C:\PW\WORK\01473817\LSIP-PLIS-LANDSCAPE\LANDING - L-1.0 - PLOTTED 1/31/2025 9:47 AM BY DENNIS, KATIE



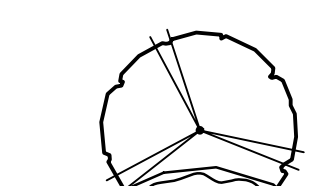

LANDSCAPE LEGEND

TREES

-  CC - AMERICAN HORNBEAM
-  FG - AMERICAN BEECH

SHRUBS

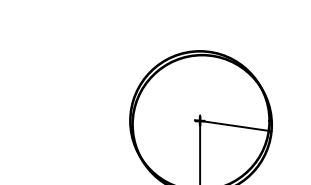
-  CO - COMMON BUTTONBUSH
-  PO - COMMON NINEBARK
-  ST - AMERICAN BLADDERNUT

PERENNIALS

-  AF - LADY FERN
-  CL - NORTHERN SEA OATS

SEED MIXES

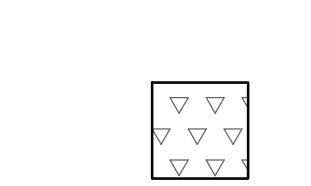
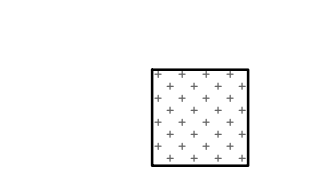
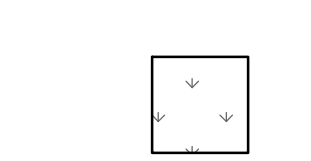
-  RAINGARDEN
-  SHORT WOODLAND
-  ECO-TURF LOW MAINTENANCE FESCUE

REV#	DATE	DESCRIPTION	CD	BY
1	1/31/25	ADDENDUM 1		

500 Church Hill Road, Suite 2500
 400 N. W. 42nd Ave.
 313.961.8500
 www.wadetrim.com



**City of St. Johns
 Fantasy Forest 2.0 Playground Improvements
 Playground Installation and Sitework**

LANDSCAPE PLAN

ISSUED FOR: MDR Review	DATE: 8/19/24	BY: CG
90% Review	12/20/24	CG
Bid	01/16/25	CG
JOB NO.	CSJ200101D	
SHEET	L-1.0	

© Wade Trim Group, Inc. Fantasy Forest Playground Improvements

Michigan Wildflower Farm – Eco-Turf Low Maintenance Fescue Mix

Seeding Rate – 7 lbs./1000 s.f. or 300 lbs./acre
\$5.25/lb.

Coverage Area	Weight	Cost
1/4 acre	75 lbs.	\$393.75
1/2 acre	150 lbs.	\$787.50
3/4 acre	225 lbs.	\$1181.25
1 acre	300 lbs.	\$1575.00

Due to fescue shortages, the EcoTurf Mix seeds are coated with ProHito™, which includes limestone with polymer, micronutrients, kelp and beneficial mycorrhizae. This added coating assures stronger germination and faster establishment.

This drought-tolerant mix provides a turf which can establish in deep shade, full sun and even the most neglected areas. Consider seeding this mix in your landscape to cut back on your lawn maintenance time and costs.

Our Eco-Turf seed mix consists of five slow growing fescues. These are not native Michigan genotype species, but are offered as an alternative to traditional turf grass mixes. Because these species are slow growing, they require less frequent mowing and since they are deep-rooted, they require minimal, if any, water or fertilizer. If a manicured appearance is required, mowing can take place but with less frequency. We mowed our Eco-Turf three times this year and mowed our traditional lawn area seven times! Some of our customers choose not to mow the Eco-Turf at all as they enjoy the soft and fine texture appearance.

The five fescues in Eco-Turf make this mix suitable for sunny/partial shade, loam/sand/gravel and well-drained clay soils. Also, once established, carefree Eco-Turf is durable in high traffic areas. The optimal time for seeding this mix is mid-to-late August through September, although seeding in mid-to-late March through May is also possible.

Prior to seeding, the planting area needs to be as weed free as possible and we recommend preparation steps laid out in our "Ten Steps to a Successful Wildflower Planting." Watering the site initially can accelerate establishment. We have not irrigated our Eco-Turf lawn ever. Fertilizing is not needed, however, if broadleaf weeds become a problem, a broadleaf herbicide can be used.

Michigan Wildflower Farm – Short Woodland Mix

40% Forbs, 60% Grasses
5 oz./1000 s.f. or 10 lbs./acre
\$14.50/oz. or \$232/lb.

Our seeds are available in any amount, no matter how small or large your project.

Coverage Area	Weight	Cost
1/4 acre	2.5 lbs.	\$360.00
1/2 acre	5 lbs.	\$720.00
3/4 acre	7.5 lbs.	\$1080.00
1 acre	10 lbs.	\$1440.00

Short Woodland Mix – Forbs

Scientific Name	Common Name
<i>Achillea millefolium</i>	Yarrow
<i>Allium cernuum</i>	Nodding Wild Onion
<i>Anemone virginiana</i>	Tall Thimbleweed
<i>Aquilegia canadensis</i>	Wild Columbine
<i>Asclepias tuberosa</i>	Butterfly Weed
<i>Echinacea purpurea</i>	Purple Coneflower
<i>Monarda fistulosa</i>	Wild Bergamot
<i>Penstemon digitalis</i>	Foxglove Beard-tongue
<i>Penstemon hirsutus</i>	Hairy Beard-tongue
<i>Rudbeckia hirta</i>	Black-eyed Susan
<i>Rudbeckia triloba</i>	Three-lobed Coneflower
<i>Symphotrichum laeve</i>	Smooth Aster
<i>Symphotrichum oolentangianis</i>	Prairie Heart-leaved Aster
<i>Symphotrichum pilosum</i>	Hairy Aster
<i>Thalictrum dioicum</i>	Early Meadow Rue
<i>Zizia aurea</i>	Golden Alexander

Mix Ratio

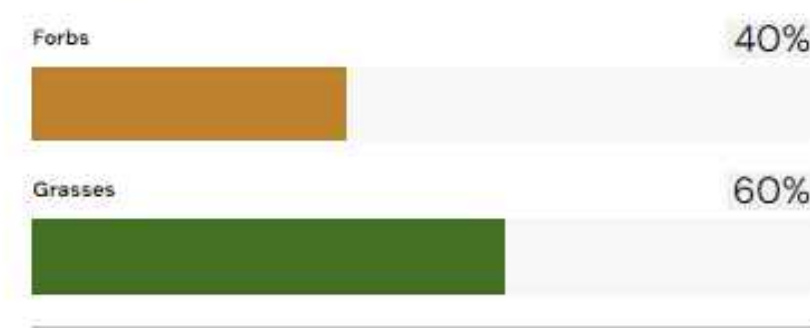

A note about cover crop...

If you are seeding on bare soil or slope, we recommend including a temporary cover crop at a rate of 15 lbs. per acre, \$3 per lb.

If you have large acreage, we suggest finding cover crop locally as they are commonly available and are heavy, adding substantially to your shipping cost with us.

Michigan Wildflower Farm – Raingarden Mix

40% Forbs, 60% Grasses/Sedge/Rush
3 oz./1000 s.f. or 6 lbs./acre
\$16.50/oz. or \$264/lb.

Our seeds are available in any amount, no matter how small or large your project.

Coverage Area	Weight	Cost
1/4 acre	1.5 lbs.	\$396.00
1/2 acre	3 lbs.	\$792.00
3/4 acre	4.5 lbs.	\$1188.00
1 acre	6 lbs.	\$1584.00

Raingarden Mix – Forbs

Scientific Name	Common Name
<i>Anemone canadensis</i>	Canada Anemone
<i>Angelica atropurpurea</i>	Angelica
<i>Asclepias incarnata</i>	Swamp Milkweed
<i>Eupatorium maculatum</i>	Joe-Pye Weed
<i>Eupatorium perfoliatum</i>	Boneset
<i>Helenium autumnale</i>	Sneezeweed
<i>Hibiscus moscheutos</i>	Swamp Rose Mallow
<i>Iris virginica</i>	Southern Blue Flag
<i>Liatris spicata</i>	Marsh Blazing Star
<i>Lobelia siphilitica</i>	Great Blue Lobelia
<i>Rudbeckia fulgida</i>	Sweet Black-eyed Susan
<i>Solidago graminifolia</i>	Grass-leaved Goldenrod
<i>Symphotrichum puniceum</i>	Swamp Aster
<i>Verbena hastata</i>	Blue Vervain
<i>Vernonia missurica</i>	Ironweed

Mix Ratio

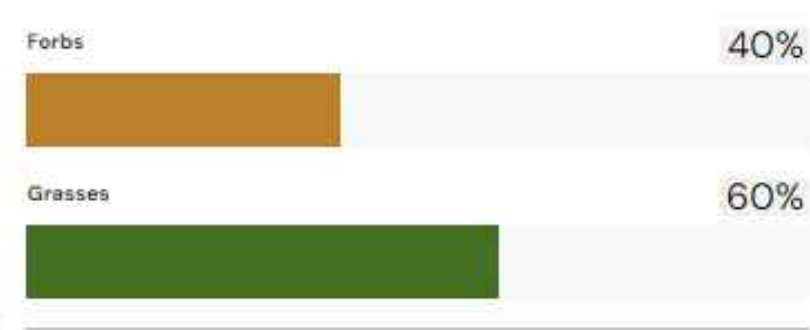

A note about cover crop...

If you are seeding on bare soil or slope, we recommend including a temporary cover crop at a rate of 15 lbs. per acre, \$3 per lb.

If you have large acreage, we suggest finding cover crop locally as they are commonly available and are heavy, adding substantially to your shipping cost with us.

LANDSCAPE NOTES

- ALL PLANTS TO BE INSTALLED IN ACCORDANCE WITH AMERICAN ASSOCIATION OF NURSERYMEN LANDSCAPE STANDARDS.
- CONTRACTOR SHALL PROVIDE A PLANTING MIXTURE MEETING THE FOLLOWING REQUIREMENTS. IF THE ENGINEER HAS ANY CONCERNS WITH THE QUALITY OF THE PLANTING MIXTURE, THE ENGINEER SHALL BE ALLOWED TWO WEEKS TO OBTAIN SOIL TEST TO DETERMINE SPECIFICATION COMPLIANCE. NO PLANT MATERIAL SHALL BE PLANTED PRIOR TO ENGINEER APPROVAL OF PLANTING MIXTURE. ALL PLANT MATERIAL SHALL BE MAINTAINED BY THE CONTRACTOR IN A VIGOROUS GROWING CONDITION DURING THIS TIME AT NO ADDITIONAL COST.
- SPACING OF PLANT MATERIALS SHALL BE AS SHOWN ON DRAWING OR ON PLANT LIST. THE ENGINEER SHALL REVIEW THE PLACEMENT OF PLANT MATERIAL PRIOR TO AND AFTER INSTALLATION, AND RESERVES THE RIGHT TO ADJUST LAYOUT TO ACCOMMODATE SITE CONDITIONS AND DESIGN INTENT.
- ALL PLANT MATERIALS SHALL CONFORM TO PLANT SCHEDULES. SIZES SHALL BE THE MINIMUM STATED ON THE PLANT LIST OR LARGER. ALL MEASUREMENTS SHALL BE IN ACCORDANCE WITH THE LATEST EDITION OF THE "A.A.N. STANDARDS FOR NURSERY STOCK."
- NO PLANT SHALL BE PUT INTO THE GROUND BEFORE ROUGH GRADING HAS BEEN FINISHED AND REVIEWED BY THE ENGINEER.
- FINAL PLANT LOCATIONS SHALL BE MARKED BY CONTRACTOR THREE WORKING DAYS PRIOR TO PLANTING FOR ENGINEER REVIEW.
- ALL PLANTED PLANTS SHALL BEAR THE SAME RELATIONSHIP TO FINISHED GRADE AS THE PLANTS ORIGINAL GRADE BEFORE DIGGING.
- PLANT MATERIAL, ESPECIALLY EVERGREENS, TO BE PLANTED HIGHER THAN NORMAL WHEN HEAVY SOIL CONDITIONS (CLAY, ETC.) PREVAIL.
- IF FOR ANY REASON ANY BALLED AND BURLAPED PLANT MATERIALS NEED TO BE STORED ON SITE LONGER THAN A 24-HOUR PERIOD, THEIR ROOT BALLS SHALL BE PROTECTED. ALL PLANTS SHALL BE THOROUGHLY WATERED EACH DAY THEY ARE STORED ON SITE. PLANTS MAY BE STORED ON SITE FOR A MAXIMUM OF TWO (2) WEEKS, OR 14 DAYS. ANY PLANTS ALLOWED TO DRY OUT AS DETERMINED BY THE ENGINEER WILL BE REJECTED.
- NO CONTAINER GROWN STOCK WILL BE ACCEPTED IF IT IS ROOT BOUND. ALL WRAPPING MATERIALS MADE OF SYNTHETIC OR PLASTICS SHALL BE COMPLETELY REMOVED AT TIME OF PLANTING.
- THE CONTRACTOR SHALL FILL PLANT PIT WITH PREPARED PLANT MIX TO 1/2 DEPTH OF ROOT BALL OR ROOT MASS, PACK FIRMLY, PUDDLE WITH WATER; THEN FOR BALLED AND BURLAPED MATERIAL, THE BURLAP AND ALL LACING (INCLUDING WIRE BASKET IF NECESSARY) SHALL BE REMOVED FROM THE UPPER 1/3 OF ROOTBALL, THEN FINISH BACKFILLING ADDING SOLID FERTILIZER TO THE PLANT MIX, PACK FIRMLY AND WATER. A SAUCER SHALL BE PLACED AROUND EVERY PLANT AND SHALL BE APPROVED PRIOR TO PLACEMENT OF ANY MULCH.
- ALL DISTURBED LAWN AREAS SHALL BE RESTORED WITH 4-INCHES OF TOPSOIL, SPREAD, FINE GRADED, AND SEEDED/SODDED AS SPECIFIED. PRIOR TO INSTALLATION OF TOPSOIL, LOOSEN SUBGRADE TO A DEPTH OF 2 INCHES. THIS WORK SHALL BE INCIDENTAL TO THE PROJECT.
- TOPSOIL SHALL CONSIST OF FRIABLE, SHREDDED, AND SCREENED SOIL REASONABLY FREE OF GRASS, ROOTS, WEEDS, STICKS, STONES OR OTHER FOREIGN MATERIALS. THE TOPSOIL MATERIAL SHALL BE APPROVED BY THE ENGINEER PRIOR TO PLACEMENT. SOIL COMPOSITION SHOULD CONTAIN AN ORGANIC CONTENT OF 2 TO 6 PERCENT AND BE CLASSIFIED AS A LOAM OR SANDY LOAM AS SPECIFIED IN THE "GUIDE FOR U.S.D.A. SOIL TEXTURAL CLASSIFICATION".
- ALL TREES AND SHRUBS ARE TO BE FERTILIZED ONCE ROOTS SYSTEM IS ESTABLISHED WITH AGRIFORM 21-GRAM FERTILIZER TABLETS AT RATES RECOMMENDED BY MANUFACTURER.
- ALL PLANTS AND STAKES SHALL BE SET PLUMB UNLESS OTHERWISE SPECIFIED.
- AT PLANTING TIME, ALL DEAD AND BROKEN BRANCHES SHALL BE PRUNED ON ALL DECIDUOUS TREES.
- CONTRACTOR SHALL APPLY ENGINEER APPROVED PRE-EMERGENT HERBICIDE, "PREEN" OR EQUAL, TO SHRUB AND GROUND COVER PLANTING AREAS AT THE TIME OF PLANTING (IF SPRING PLANTED) OR THE FOLLOWING SPRING. CONTRACTOR SHALL ENSURE THE PLANT MATERIALS ARE RESISTANT TO THE HERBICIDES PROPERTIES. HERBICIDE SHALL BE APPLIED ACCORDING TO MANUFACTURERS SPECIFICATIONS AND IN ACCORDANCE WITH SOUND HORTICULTURAL PRACTICES.
- ALL TREES, SHRUBS AND PERENNIAL GROUND COVER SHALL RECEIVE A MINIMUM DEPTH OF THREE INCHES DOUBLE SHREDDED HARDWOOD BARK MULCH, WHERE PLANT BEDS MEET PAVEMENTS, LAWN, OR STEEL EDGING CUT THE GRADE TO ALLOW FOR MULCH AND THREE-INCH DROP FROM ADJOINING FINISH GRADE.
- ALL PLANT BEDS SHALL BE EXCAVATED TO A MINIMUM DEPTH OF 8-INCHES AND BACKFILLED WITH SPECIFIED PLANT MIX AS PER PLANTING BED DETAILS. BEDS SHALL BE EDGED WITH METAL EDGING AROUND PERIMETER. ALL EDGING SHALL BE 4" WIDE - 12 GAUGE STEEL, COLOR BLACK. CONTRACTOR SHALL LAYOUT EDGING FOR APPROVAL AND INSTALL PER MANUFACTURERS RECOMMENDATIONS.
- PLANTS SHALL BE WATERED BEFORE AND AFTER PLANTING IS COMPLETE. ALL TREES MUST BE STAKED, FERTILIZED AND MULCHED AND SHALL BE GUARANTEED TO EXHIBIT A NORMAL GROWTH CYCLE FOR AT LEAST ONE (1) FULL YEAR FOLLOWING PLANTING. ALL DISEASED, DAMAGED, OR DEAD MATERIAL SHOWN ON THE SITE PLAN SHALL BE REPLACED BY THE END OF THE FOLLOWING GROWING SEASON.
- APPLICATIONS OF FERTILIZER BEYOND THE INITIAL TOPSOIL AND SEEDING SHALL BE A FERTILIZER WITH NO PHOSPHOROUS.
- CONTRACTOR SHALL INFORM LANDSCAPE ARCHITECT OF ANY FOUND DISCREPANCIES IN WRITING PRIOR TO INSTALLATION.
- PLANTING SOIL AND MULCH INSTALLATION IS INCIDENTAL TO LANDSCAPE PAY ITEMS.

PLANTING MIXTURE NOTES

- MIXTURE SHALL BE A MIXTURE OF 6 PARTS TOPSOIL, 4 PARTS MEDIUM-COARSE SAND, AND 1 PART COMPOST. ADD FERTILIZER AT THE QUANTITY AS RECOMMENDED BY THE MANUFACTURER. PLANTING MIXTURE SHALL BE FREE FROM STICKS, STONES, SOD CLOUDS, OR OTHER MATERIAL WHICH MIGHT LEAVE POCKETS AROUND THE ROOTS.
- TOPSOIL
 - TOPSOIL SHALL BE FERTILE, FRIABLE, SANDY CLAY LOAM WITHOUT ADMIXTURE OF SUBSOIL. TOPSOIL IS TO BE FREE OF GLASS, STONES GREATER THAN ONE (1) INCH IN ANY DIMENSION, WEEDS, UNDESIRABLE GRASSES AND OTHER EXTRANEUS MATERIALS. TOPSOIL SHALL HAVE THE FOLLOWING RANGE OF VALUES:
 - pH 5.0 TO 7.5
 - SOLUBLE SALTS 500 PPM MAX
 - ORGANIC CONTENT 5% TO 30%
 - SLT CONTENT 35% TO 50%
 - CLAY CONTENT 5% TO 10%
 - DELETERIOUS MATL* 5% MAX
 - *ROCK, GRAVEL, STONE, STICKS, ROOTS, SOD, ETC.
 - TOPSOIL IS TO BE FINAL SCREENED THRU A 5/8" MAXIMUM MESH SCREEN PRIOR TO DELIVERY TO THE PROJECT SITE. ENGINEER SHALL REVIEW SOURCE AND FINAL SCREEN RESULTS PRIOR TO RELEASE OF TOPSOIL. CONTRACTOR SHALL SUBMIT A CERTIFIED ANALYSIS OF THE TOPSOIL FROM EACH SOURCE TO THE ENGINEER. TOPSOIL SHALL BE PLACED IN 4-INCH MINIMUM THICKNESS THROUGHOUT.
- SAND FOR PLANTING MIXTURE SHALL BE CLEAN, MEDIUM-COARSE, UNGRADED SAND CONFORMING TO ASTM C3 FOR FINE AGGREGATES.
- COMPOST SHALL BE COMPOSTED PINE BARK FINES OR OTHER HIGH-LIGNIN BARK FROM SPRUCE, FIR, OR OTHER CONIFERS.

LANDSCAPE SCHEDULE

	SYMBOL	CODE	BOTANICAL NAME	COMMON NAME	SIZE	QTY	SPACING
TREES		CC	CARPINUS CAROLINIANA	AMERICAN HORNBEAM	2.5" CAL.	2	PER PLAN
		FG	FAGUS GRANDIFOLIA	AMERICAN BEECH	2.5" CAL.	2	PER PLAN
SHRUBS		CO	CEPHALANTHUS OCCIDENTALIS	COMMON BUTTONBUSH	#3	24	PER PLAN
		PO	PHYSOCARPUS OPULIFOLIUS	COMMON NINEBARK	#3	26	PER PLAN
		ST	STAPHYLEA TRIFOLIA	AMERICAN BLADDERNUT	#3	4	PER PLAN
PERENNIALS		AF	ATHYRIUM FILIX-FEMINA	LADY FERN	#1	60	PER PLAN
		CL	CHASMANTHIUM LATIFOLIUM	NORTHERN SEA OATS	#1	72	PER PLAN
SEED MIXES							
			RAINGARDEN			1,706 S.F.	
			SHORT WOODLAND			11,397 S.F.	
			ECO-TURF LOW MAINTENANCE FESCUE			4,738 S.F.	

REV#	DATE	DESCRIPTION
1	1/31/25	ADDENDUM 1

500 South Main Street, Suite 2500
Ann Arbor, MI 48106
313.961.8500
www.wadetrims.com

WADE TRIM

City of St. Johns
Fantasy Forest 2.0 Playground Improvements
Playground Installation and Sitework

LANDSCAPE DETAILS

ISSUED FOR: DATE: BY:
MDNR Review 8/19/24 CD
90% Review 12/20/24 CD
Bid 01/16/25 CD

JOB NO. CSJ200101D
SHEET

L-2.1

Fantasy Forest Playground Improvements